

Indigo™ Series 1800 Ice Cube Machine

Model: IR-1800A ID-1802A IR-1890N ID-1803W
 IY-1804A IY-1805W IY-1894N ID-1892N



Indigo Series i-1800
Ice Machine on B-970 Bin

Designed for operators who know that ice is critical to their business, the Indigo™ Series ice machine's preventative diagnostics continually monitor itself for reliable ice production. Improvements in cleanability and programmability make your ice machine easy to own and less expensive to operate.

- **Space-Saving Design** – Up to 1,860 lbs. (845 kgs.) daily ice production and only 48" (121.92 cm) wide.
- **Intelligent Diagnostics** – provide 24 hour preventative maintenance and diagnostic feedback for trouble free operation.
- **Acoustical Ice Sensing Probe** – for reliable operation in challenging water conditions.
- **EasyRead Display** – communicates operating status, cleaning reminders, and asset information through a blue illuminated display.
- **Programmable Ice Production** – by On/Off Time, Ice Volume or Bin Level (with accessory bin level control) further improves energy efficiency and savings.
- **Easy to Clean Foodzone** – Hinged front door swings out for easy access. Removable water-trough, distribution tube, curtain, and sensing probes for fast and efficient cleaning. Select components made with AlphaSan® antimicrobial.
- **DuraTech™ Exterior** – provides superior corrosion resistance. Stainless finish with innovative clear-coat resists fingerprints and dirt.
- Available **LuminIce™ Growth Inhibitor** controls the growth of bacteria and yeast within the foodzone.

Ice Machine Electric

208-230/60/1 standard
(208-230/60/3 and 230/50/1 also available.)

Minimum circuit ampacity:

Air-cooled:	23.8 1ph	15.4 3ph
Water-cooled:	22.4 1ph	14.0 3ph
Remote-cooled:	23.4 1ph	15.0 3ph

Maximum fuse size:

Air-cooled:	40 1ph	25 3ph
Water-cooled:	40 1ph	25 3ph
Remote-cooled:	40 1ph	25 3ph

Specifications

BTU Per Hour:
30,000 (average),
and 35,000 (peak)

Refrigerant:
R-404A CFC-free

Operating Limits:

- Ambient Temperature Range:
35° to 110°F (1.7° to 43.3°C)
Water Temperature Range:
35° to 90°F (1.7° to 32.2°C)
- Water Pressure Ice Maker
Water In:
Min. 20 psi (137.9 kPa)
Max. 80 psi (551.1 kPa)



Ice Shape

Half Dice
3/8" x 1 1/8" x 7/8"
(.95 x 2.86 x 2.22 cm)

Dice
7/8" x 7/8" x 7/8"
(2.22 x 2.22 x 2.22 cm)

Regular
1 1/8" x 1 1/8" x 7/8"
(2.86 x 2.86 x 2.22 cm)





Indigo™ Series 1800 Ice Cube Machine

i-1800 on B-970 Storage Bin

- Ⓐ Electrical Entrance (2) Options
- Ⓑ 1/2" (1.27 cm) F.P.T. Water Condenser Outlet (water-cooled units)
- Ⓒ 3/8" (0.95 cm) F.P.T. Water Condenser Inlet (water-cooled units)
- Ⓓ 3/8" (0.95 cm) F.P.T. Ice Making Water Inlet
- Ⓔ 1/2" (1.27 cm) F.P.T. Ice Making Water Drain
- Ⓕ 1/2" (1.27 cm) Auxillary Base Drain Socket
- Ⓖ 3/4" (1.91 cm) Bin Drain
- ↻ Air flow for air-cooled models

Installation Note

Air Cooled clearance:

- Top: 24" (61.0 cm)
- Sides: 24" (61.0 cm)
- Back: 5" (30.5 cm)

Water Cooled clearance:

- Top/Sides: 8" (20.3 cm)
- Back: 5" (12.7 cm)

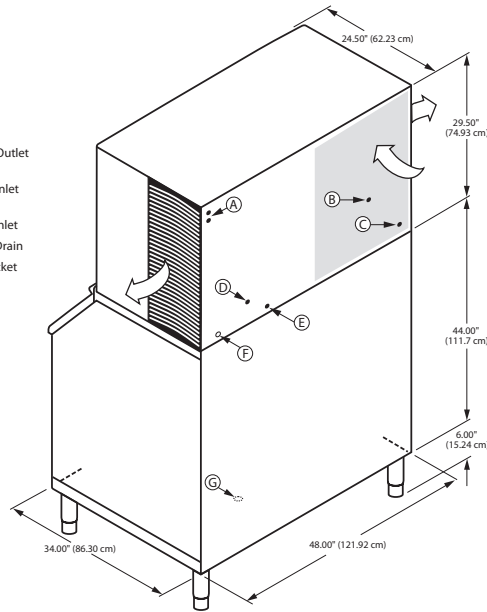

Space-Saving Design



**i-1800
B-970**

Height	79.50"
	201.90 cm
Width	48.00"
	121.92 cm
Depth	34.00"
	86.30 cm
Bin Storage	710 lbs.
	322.2 kgs.

Height includes adjustable bin legs 6.00" to 8.00", (15.24 to 20.32 cm) set at 6.00" (15.24 cm).

Specifications

Model	Ice Shape	Ice Production 24 Hours		Power Usage kWh/100 lbs. @90°Air/70°F 1 Ph	Potable Water Usage/100 lbs. 45.4 kgs. of Ice
		70°Air/ 50°F Water	90°Air/ 70°F Water		
AIR-COOLED IR-1800A	regular 	1,790 lbs.	1,430 lbs.	5.07	22.3 Gal. 84.4 L
		814 kgs	650 kgs		
	ID-1802A	1,840 lbs. 836 kgs	1,430 lbs. 650 kgs	5.16	22.3 Gal. 84.4 L
IY-1804A	half-dice 	1,860 lbs. 845 kgs	1,455 lbs. 661 kgs	5.27	22.3 Gal. 84.4 L
WATER-COOLED ID-1803W	dice 	1,850 lbs.	1,640 lbs.	3.93	22.3 Gal. 84.4 L
		841 kgs	744 kgs		
	IY-1805W	half-dice 	1,790 lbs. 814 kgs	1,650 lbs. 750 kgs	3.92
* Water-cooled Condenser Water Usage / 100 lbs. /45.4 kgs. Of Ice: 181 gal. / 685 L. * Water-cooled models are excluded from ENERGY STAR qualification.					
REMOTE-COOLED IR-1890N	regular 	1,690 lbs.	1,420 lbs.	4.99	22.3 Gal. 84.4 L
		768 kgs	645 kgs		
	ID-1892N	1,775 lbs. 807 kgs	1,495 lbs. 680 kgs	4.96	22.3 Gal. 84.4 L
IY-1894N	half-dice 	1,810 lbs. 823 kgs	1,445 lbs. 657 kgs	5.06	22.3 Gal. 84.4 L

Order ice storage bin separately. To order 3 phase add "3" suffix to model # (ID-1202A3).

Accessories

LuminIce™ Growth Inhibitor
reduces yeast and bacteria growth for a cleaner ice machine.



Bin Level Control
Allows ice bin level to be automatically set. Built-in LED light illuminates bin.



Arctic Pure® Water Filters
Reduces sediment and chlorine odors for better tasting ice.



AuCS®
schedules and performs routine ice machine cleaning automatically.

